

# EM100 Insulation Blowing Machine For Beginners and Handymen

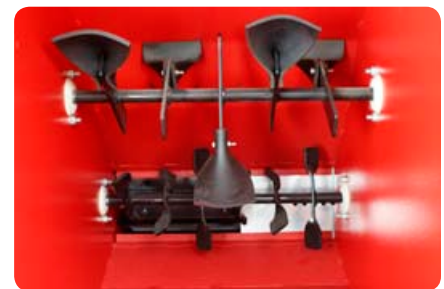

- ▶ Tough and compact insulation blowing machine
- ▶ Powerful blower with increased lifetime
- ▶ Good material conditioning for open blowing
- ▶ 230 V / 50 Hz / 10 A electrical connection
- ▶ CE compliant



Agitator

Compact tough insulation blowing machine for loose insulation materials like cellulose, glass wool, granules and more insulation materials authorised by building inspection authorities.

The EM100 can be used for open blowing, dry injection and damp-spray. The easy-to-handle and the clearly arranged setting options make it ideal for certified specialists as well as handyman applications.



Setting of the airlock feed gate

Technical data	
Power/material processing speed*	320 kg/h
Hopper	0,145 m <sup>3</sup> / support for bags
Airlock outlet	NW63 (2 1/2")
Dimensions (L x W x H)	600 x 500 x 1300 mm
Unladen weight	105 kg
Filling height	1300 mm
Machine control	Cable control (optional remote control FFB400)
Shredding and conditioning	2 horizontal agitator shafts
Airlock material	Sheet steel
Airlock feed gate	14 steps, manual
Air feed unit	High-powered centrifugal fan
Air flow volume (max.)	20 - 190 m <sup>3</sup> /h
Conveying height* without/with amp. (max.)	15 m
Hose length (max.)	40 m
Adjustable conveying pressure (max.)	250 mbar
Installed air power (adjustable)	1,45 kW
Installed motor power	0,75 kW
Power rating	2,0 kW
Power supply	230 V / 50 Hz / 10 A
Material packing density (max.)	145 kg/m <sup>3</sup>

All values approximate.

\* Maximum value, depending on use, material and delivery.  
Data based on average cellulose insulation material.

Easy operating elements with mains voltage control display



High mobility with little force

# Dimensions, Functions and Equipment

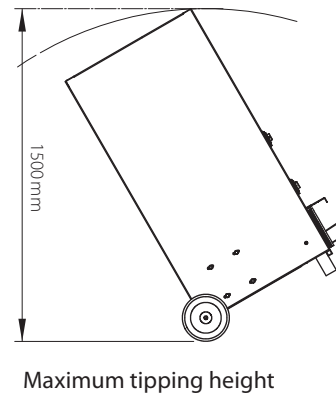
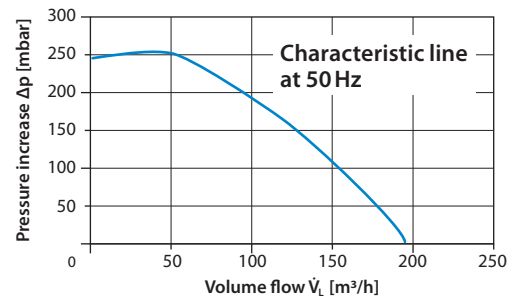
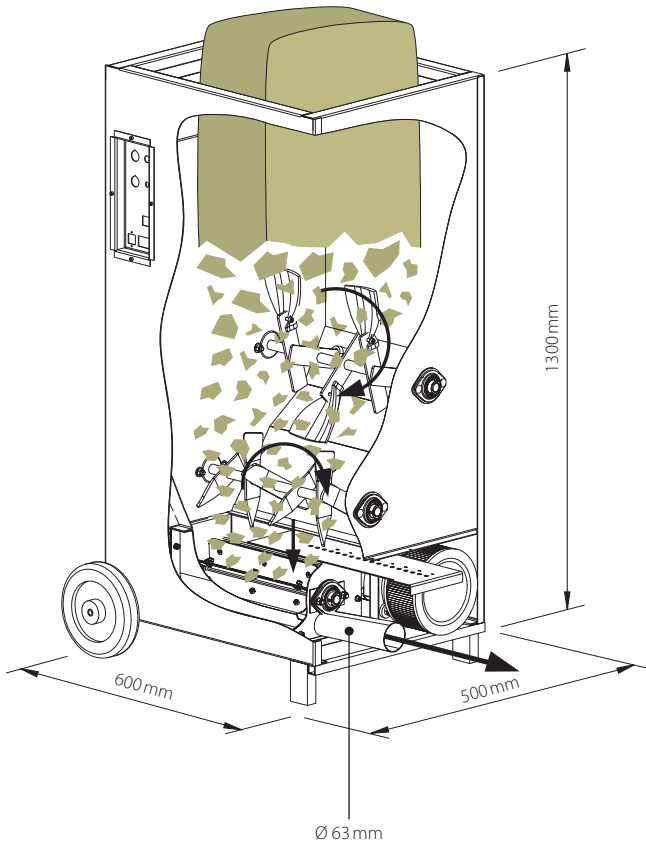

**Auxiliary equipment adapter EM100**  
For connection of auxiliary equipment  
(prod. no. 5436)

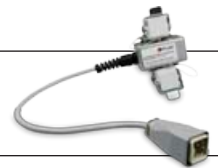

## Purchased party package EM100:

- ▶ Cable control KFB3; Product no. 3821
- ▶ 25m control cable (circle); Product no. 4220
- ▶ Power adaptor 230 V; Product no. 066



## Optional:

- ▶ FFB500, remote control bidirectional; Product no. 6708
- ▶ Sack support; Product no. 4714
- ▶ Pressure gauge; Product no. 084
- ▶ Socket spanner SW13; Product no. 832
- ▶ S-hook for cable stowage; Product no. 4367

